

HYDRANT & AIR VALVE ISOLATORS STANDARD PN35

DN 80 & DN 100. PROVIDING ISOLATION OF ATTACHED APPURTENANCE FOR MAINTENANCE



Ductile Iron body and top cover for high strength and impact resistance

EPDM encapsulated plug for longevity and reliable sealing

Thermally bonded polymeric coating for long life protection

End connections available as DN 80 or DN100 Figure B6 connections

Allows easy attachment of spring hydrant, air valve or screwed outlet

O-ring seals replaceable under full operating pressure.

Isolated fasteners for long life corrosion protection.

DESCRIPTION

Hydrant & Air Valve Isolators provide isolation of the attached appurtenance for maintenance purposes

GENERAL APPLICATION

Hydrant and Air Valve Isolators can be used in conjunction with spring hydrants, air valves or screwed outlets to provide isolation of the appurtenance for maintenance purposes

TECHNICAL DATA

Size Range DN 80 and DN 100

Allowable Operating Pressures
3500kPa

Maximum Temperature 50°C

End Connections
Flanged to AS 4087 Fig B6

Certifications
AS/NZS 4020
Testing of products for use in contact with drinking water



HYDRANT & AIR VALVE ISOLATORS STANDARD PN35

DN 80 & DN 100. PROVIDING ISOLATION OF ATTACHED APPURTENANCE FOR MAINTENANCE

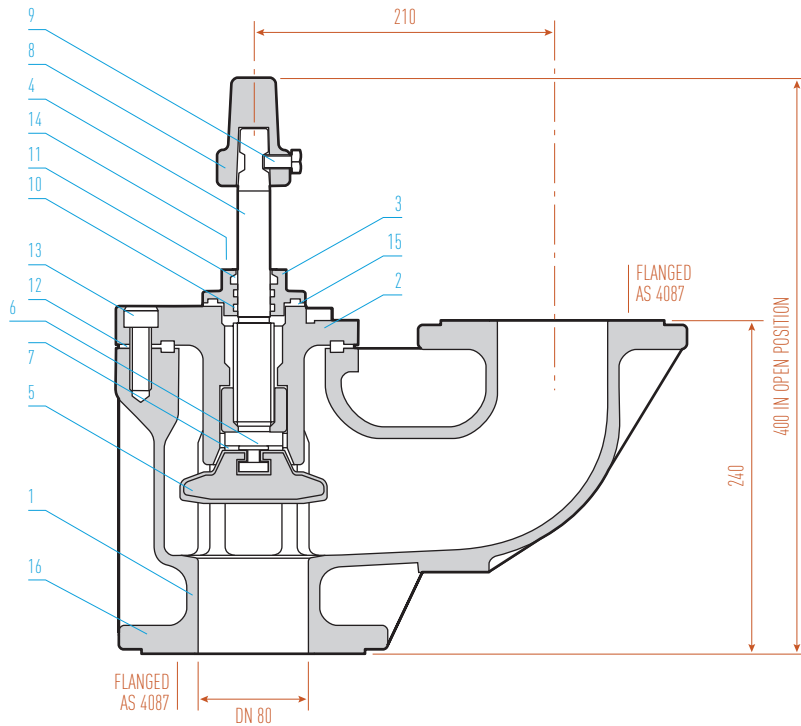

PARTS LIST

| No | Description Material / Standard |
|----|--|
| 1 | Body Ductile Iron / AS 1831-400/15 |
| 2 | Top Cover Ductile Iron / AS 1831-400/15 |
| 3 | Seal Retainer Gun Metal / AS 1565 C83600 |
| 4 | Spindle Stainless Steel / ASTM A276 431 |
| 5 | Plug Ductile Iron/EPDM / AS 1831-400/15 AS 1646 |
| 6 | Nut Gun Metal / AS 1565 C83600 |
| 7 | Washer, Anti-Friction Acetyl |
| 8 | Spindle Cap Ductile Iron / AS 1831-400/15 |
| 9 | Hex Head Screw Stainless Steel / ASTM A276 316 |
| 10 | O-Rings Nitrile Rubber / AS 1646 |
| 11 | Wiper Ring Nitrile Rubber / AS 1646 |
| 12 | Body Gasket EPDM Rubber / AS 1646 |
| 13 | Socket Head Screw Stainless Steel / ASTM A276 316 |
| 14 | Socket Head Screw Stainless Steel / ASTM A276 316 |
| 15 | Seal Retainer Gasket EPDM Rubber / AS 1646 |
| 16 | Coating Thermally Bonded Polymeric / AS/NZS 4158 |

DN80 & DN100 - PN35

| CODE | Size (mm) | Description |
|------------|-----------|-----------------------------------|
| VHDF0808S7 | 80 | 80 B6/80 B6 CC H&AV ISOLATOR FC |
| VHDF1010S7 | 100 | 100 B6/100 B6 CC H&AV ISOLATOR FC |

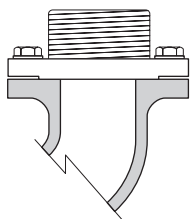

SCREWED OUTLET

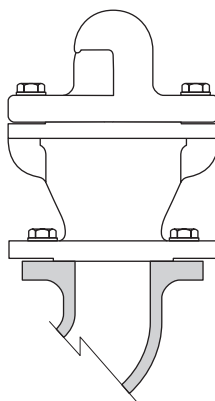

SPRING HYDRANT

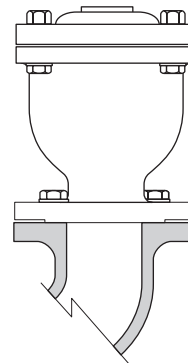

AIR VALVE